

Notes

1. **General**
 - 1.1. Tank constructed from Polyethylene.
 - 1.2. The Vessel is to be installed in a location that will not cause a nuisance, obstruct fire access, cannot be vandalised or be damaged by vehicles.
 - 1.3. The Vessel must have ease of access to pumpout point for maintenance.
 - 1.4. A hose tap fitted with RPZD backflow protection (as per AS/NZS 3500).
 - 1.5. Non standard installations require Halgan approval.
 - 1.6. Risers are prohibited for Pump station Vessels.
2. **Installation above ground**
 - 2.1. Pump station must be placed on a level concrete base designed to withstand pump station loadings.
 - 2.2. Ensure tank is protected from external damage.
 - 2.3. All stormwater must be diverted away from the Vessel to prevent undermining of foundation.
3. **Installation below ground**
 - 3.1. All connections to the Halgan Pumpstation shall be in accordance with the appropriate authorities.
 - 3.2. Any excavation exceeding 1.5m in depth shall comply with the construction safety Acts and Regulations.
 - 3.3. The Vessel needs to be filled prior to backfilling.
 - 3.4. Once backfill is completed, remove water from vessel so not allowing water ingress in level sensors and corrosion of pumps in none operational state.
4. **Excavation dimensions**
 - 4.1. The excavated hole width shall be kept as narrow as practicable. The depth shall not be greater than 150mm and the width not greater than 75mm of the tank dimensions.
5. **Bedding/Backfill**
 - 5.1. The bedding/backfill material shall be Blue Metal granular material up to 10mm diameter.
 - 5.2. The bedding/backfill shall be thoroughly compacted by tamping at 300 mm layers.
 - 5.3. The bedding/backfill material shall encase the whole tank.
 - 5.4. Foreign material such as builder's waste, bricks, and concrete shall not be used as backfill.
 - 5.5. The backfill shall be compacted to restore the excavated hole as near as practicable to the normal ground.
6. **PipeWork**
 - 6.1. An isolation valve must be provided in the common discharge line and a non return valve must be provided on each pump discharge.
 - 6.2. For free standing pumps a barrel union/quick release coupling must also be provided.
 - 6.3. For guiderail installations a disconnection flange or barrel union should be provided to facilitate service of check valves.
 - 6.4. The valves and disconnection points should be located as close as practical to the top of the pump station and be accessible from the manhole opening.
7. **Hydrostatic Lift - Ballast Requirements**
 - 7.1. Buried tanks can float when empty, if ground is water charged. To avoid this, the total weight of the tank, overburden (backfill material above the tank) and any concrete needs to exceed the weight of water for the displaced volume.
 - 7.2. We recommend a qualified engineer to be used to design requirements based on the site conditions and backfill material.
 - 7.3. The deadweight of the empty tank and applicable soil loads must be at least 1.5 times the force due to hydrostatic uplift. If the concrete slab combined with overburden is inadequate, anchorage should be designed and installed on tanks.

HALGAN™ HT1050 HOLDING TANK DETAIL

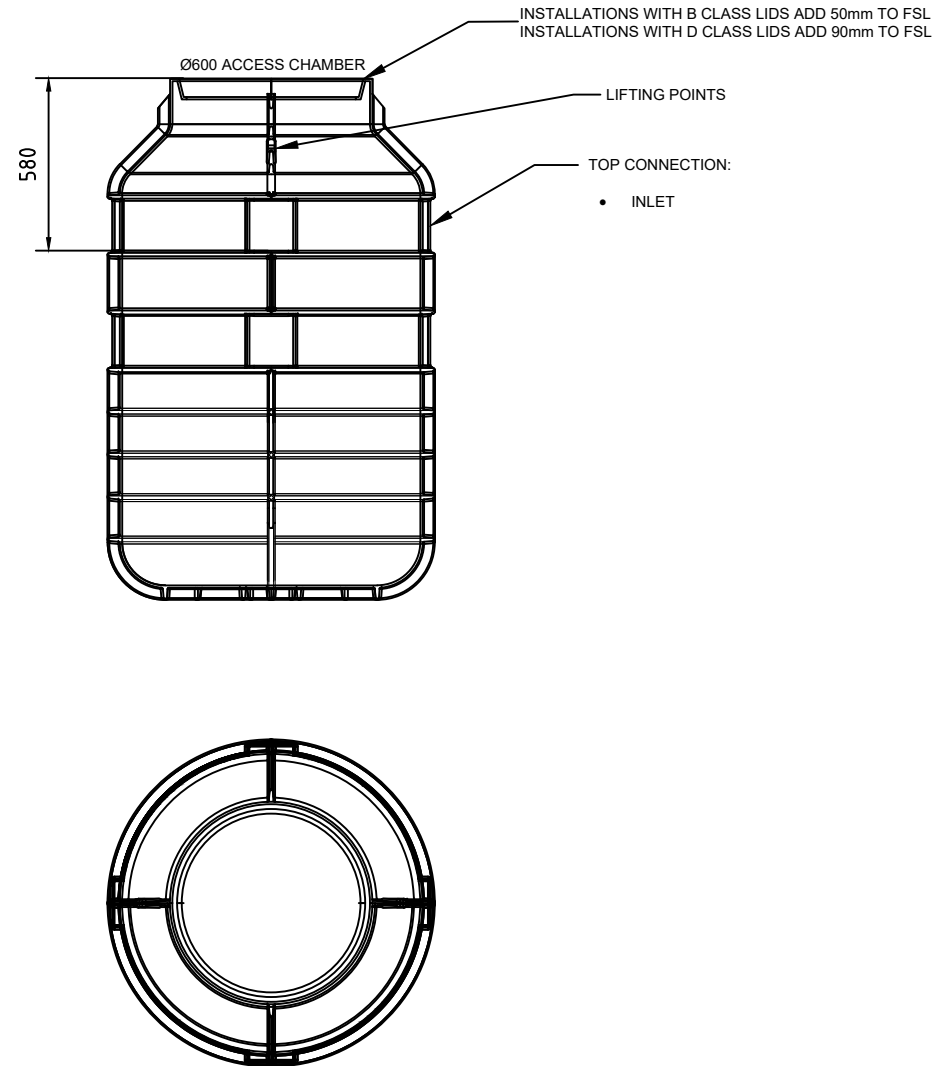

HALGAN™ HT1050 PUMPSTATION DIMENSIONS					
DIMENSIONS DO NOT INCLUDE PIPEWORK OR ACCESS LIDS					
MODEL	HEIGHT	WIDTH	LENGTH	VOLUME	WEIGHT
HT1050	1730mm	1070mm	1070mm	1050 L	80 KG

REV	DATE	DESCRIPTION	BY	CHKD	APP
C	23.05.2018	DETAIL DESIGN UPDATED	LB	IH	KH
B	12.04.2018	DETAIL DESIGN UPDATED	LB	JB	KH
A	06.10.2017	DETAIL DESIGN	LB	JB	KH

THIS DRAWING AND THE INFORMATION CONTAINED HEREON ARE THE PROPERTY OF HALGAN PTY LTD AND MUST NOT BE COPIED, REPRODUCED OR USED WITHOUT THE WRITTEN PERMISSION OF HALGAN PTY LTD.
DO NOT SCALE IF IN DOUBT ASK



Freecall 1800 626 753
22, Ethel Avenue
Brookvale NSW 2100
admin@halgan.com.au
www.halgan.com.au

MEASUREMENTS CAN VARY ± 3%

HALGAN™ HT1050 HOLDING TANK DETAIL

DRWGR	DATE	SCALE	REV.
LB	23.05.2018	-	A4
CHKD			
IH			
DRW. NO.	HT1050		C