

BIANCO NXT

controls

Single Pump Protection and Control Module

Single Phase

BIA-nXt-SPC 1-22 PN 811195

Three Phase

BIA-nXt-SPC 3-40 PN 811196

BIA-nXt SPC 3-11 PN 811197

BIA-nXt SPC 3-15 PN 811198

Installation and Operation Manual



A. Shortcuts

Switching between AUTO and MANUAL:

PRESS then release the **MODE** button

Note: All pump protections are valid in MANUAL state

Switching to Manual if the controller is in LOCK MODE:

PRESS & HOLD the **MODE** button for 5 seconds

Lock parameter # 011 in the Expert Menu Pg 13

Accumulated Run time:

Set Control to MANUAL.
Press & hold **STORE** then
press **START**
Press **STOP** to exit

Error log:

- Set Control to MANUAL
- Ensure no pumps are running.
- PRESS & HOLD the **STOP** or button, then SHORT PRESS the **MODE** button
- Press **MODE** to scroll
- Press **STOP** or to exit

Alarm Mute:

Press the **STOP** button to mute the alarm.
It will now beep every 5 minutes.

Auto resets after 24Hrs

Alarm Test:

Inside the controller on the display PCB is an ALARM TEST button

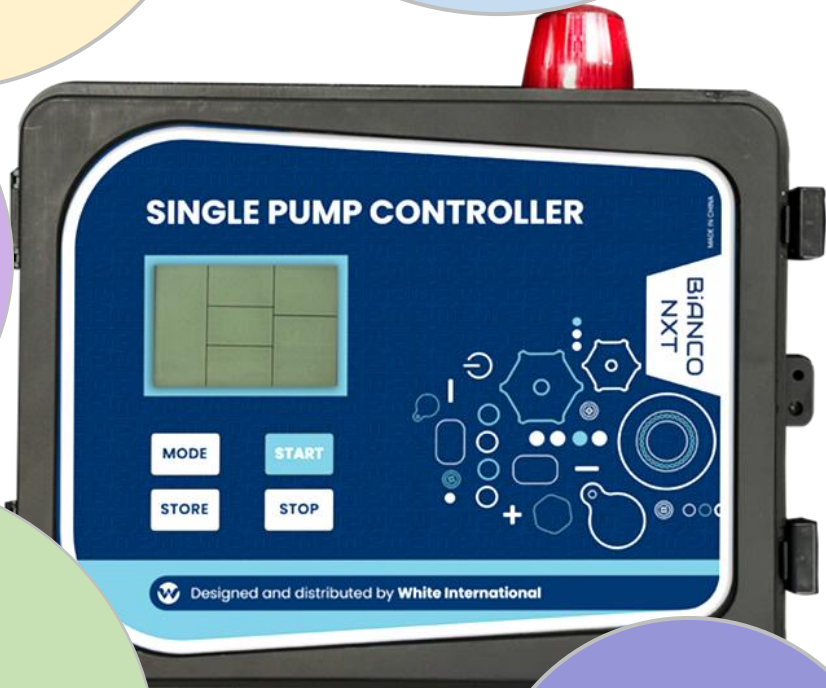

B. Shortcuts cont

Calibrating the controller to the pump

In MANUAL, short press **START**
Allow the pump to run and the current draw to stabilise.

Once you are satisfied the pump is in its 'normal' operating range, short press **STORE** The controller should chirp.

The controller calibration value can be checked and adjusted from the User Menu

[Parameter #015](#)

To clear the calibration

With the pump stopped and the controller in MANUAL mode, PRESS & HOLD the **STOP** or for 5 seconds

USER programming menu

In MANUAL, PRESS & HOLD the **STORE** button for 5 sec.

[Page 14](#)

EXPERT programming menu

In MANUAL, press **STORE** then **MODE** button and hold BOTH for 5 seconds

[Page 13](#)

Programming:



STORE cycles through the parameters

START increases a value

STOP decreases a value



Short press **MODE** to store a value and return to the main menu

Press **STORE** for 5 sec to save changes and exit the parameter menu

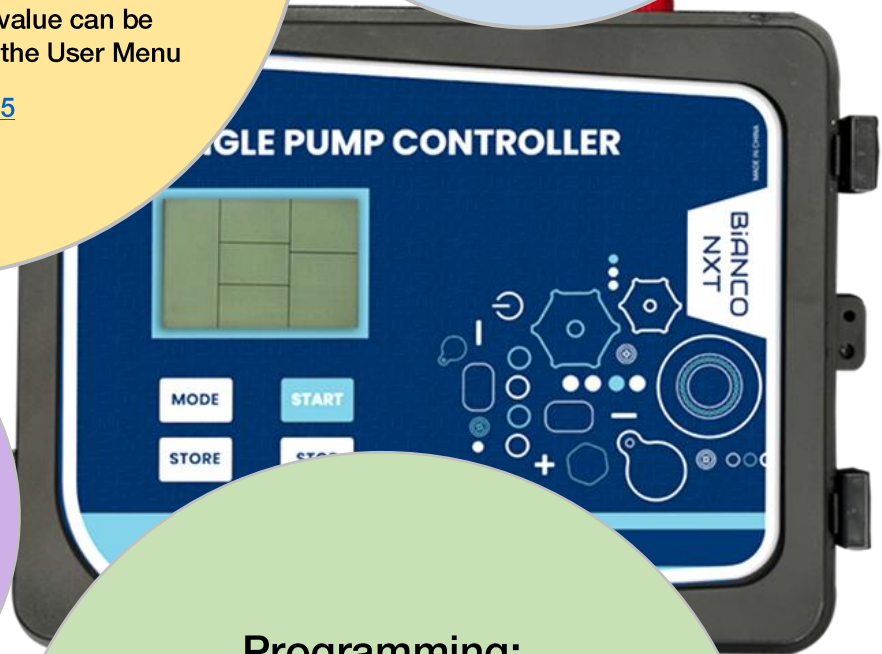

1. Introduction

Thank you for choosing a BiANCO NXT-SPC (Single Pump Control and protection module). The NXT-SPC is a module intended to control and protect an individual pump. The user can select a control logic sequence to match their application and enjoy the benefits of superior control and protection for the pumps.

There are 3 primary control logic modes:

- ‘Drainage’ where control is concentrated at the source
- ‘Boosting’ which references pressure switching on the delivery side for control
- ‘Transfer’ which is a mix of source and destination control

NXT-SPC has 2 x passive dry contacts and is equipped with a RS485 modbus interface to connect to a BMS

The LCD screen displays the pump running state and provides the user a wealth of useful information.

The controller is easy to set up with an initial push button calibration and individual parameters can be fine-tuned.

A NXT-SPC controller is particularly useful where there is the need to control and protect pump installations managing the automatic operation through a variety of switching methods without the need to create a bespoke control solution.





2. Warnings and Cautions

	Read the manual carefully before starting
	Prior to starting installation or maintenance the controller must be disconnected from the power supply.
	Any changes or modification to the wiring must be carried out by competent, skilled and suitably qualified personnel only.
	A qualified electrician should correctly size and install circuit breakers to protect the power supply. The fitment of additional surge protection is recommended as good practice.
	Never open the cover while controller is connected to electrical supply. Disconnect and allow the internal electronics to discharge before opening the cover
	This appliance is not intended for use by persons (including children) with reduced physical, sensory or mental capabilities, or lack of experience and knowledge, unless they have been given supervision or instruction concerning use of the appliance by a person responsible for their safety. Children should be supervised to ensure that they do not play with the appliance.
	Ensure the controller is a suitable size for the pump motor (see Section 6, Page 7: Technical Data). Size according to full load current amperage.

3. Contents

A/B. Shortcuts	2 - 3
1. Introduction	2. Warnings and Cautions.....
3. Contents	4. Symbols used in this manual.....
5. Modes of Operation.....	6
6. Technical Specifications	7
7. Display.....	8 - 9
8. Electrical Connections.....	10
9. Modbus.....	12
10. Parameter Calibration	12
11. Program Parameters	13
12. Understanding the control logic	15
12. Quick guide: Drainage Mode, float connected to pump.....	17
13. Quick guide: Drainage Mode, floats connected to control.....	18
14. Quick guide: Transfer – source/destination control	19
15. Quick guide: Pressure Boosting – switched input	20
16. Quick guide: Drainage Mode, 4–20mA level transmitter.....	21
17. Quick guide: Transfer – source/destination control 4-20mA.....	22
18. Quick guide: Pressure Boosting 4-20mA.....	23
19. Backup power supply / External Alarm	24
20. Fault Messages.....	25
21. Accessories	26
21. Warranties – Terms and Conditions.....	27

4. Symbols used in this manual

	Warning - Electrical safety
	Warning – Potential consequences of use outside of intended application(s). Includes environmental condition warnings.
	Mandatory warning
	Warning to disconnect power
	Read carefully

5. Modes of Operation



On the main PCB there is a 4 position 'Dip Switch'

To alter the control logic to suit an application, the installer must select the appropriate switch position.

After selecting the desired switch position, **cycle the controller power to apply the setting.**

Binary	Switch position	Control logic - Applications
000		'Drainage' Mode where the control inputs (generally level floats or probes) are located at the source. (default)
010		'Drainage' Mode where the level control input is managed by a flexible float on the pump. No bridge – terminals #5 and #7
111		'Pressure Boosting' Mode. Main control via (N/C) pressure switch. Supports run / no run level protection at the source via floats or probes.
101		'Transfer' Mode. Main control via control inputs (floats or probes) at destination or by a pressure switch on the delivery line. Supports run / no run level protection at the source.
0*		OTA/OTB terminal enabled (default)
1*		Enables the connection of a PT00 temperature sensor (i.e. pump over-temp sensor) A separate PT100 temperature sensor expansion module is required
011*		'Drainage' Mode with overflow alarm through a 4-20mA level transmitter.
001*		'Pressure Boosting' Mode controlled via a 4-20mA pressure transmitter. Supports run / no run level protection at the source via floats or probes.
100*		'Transfer Mode' with 4-20mA level transmitter at the destination. Supports run / no run level protection at the sources via floats or probes.

When first powered on, the controller will display the current dipswitch operating mode (binary code), and the software version.

Current software V1.01

010	Dipswitch Position
101	Software

6. Technical Specifications

Controller Modes	Automatic or Manual pump operation. Liquid level control via float switch, electrode probes OR 4-20mA level transducer. Pressure control via pressure switch or 4-20mA transducer
Protection functions: <i>(three phase only:</i> Phase reversal, Phase Imbalance) Open phase protection Repeated start, Short circuit, Over temperature <i>Over temperature requires an optional relay</i>	Dry run (Underload), Overload, Pump Stalled, Transient surge, Under voltage, Over voltage, <i>(three phase only:</i> Phase reversal, Phase Imbalance) Open phase protection Repeated start, Short circuit, Over temperature <i>Over temperature requires an optional relay</i>
Input Voltage	Single phase 230V +10% -6% Three phase 415V +10% -6%
Rated output power	SPC 1-22 nominal 0.37 to 2.2 kW P2 power (max 16A input) SPC 3-40 nominal 0.37 to 4 kW P2 power (max 12A input) SPC 3-11 nominal 2.2 to 11 kW P2 power (max 25A input) SPC 3-15 nominal 7.5 to 15 kW P2 power (max 32A input)
Minimum working current	SPC 1-22 = 1 amp SPC 3-40 = 1 amp SPC 3-11 = 5 amp SPC 3-15 = 10 amp
Working temp	-25 to +55 deg C 20% to 90% relative humidity, non-condensing
Controller size	342mm wide, 253mm tall, 130 deep. IP54
Trip response times (set)	Open phase – Less than 2 sec Short circuit – less than 0.1 sec
Trip Voltage (User adjustable)	Over voltage: Default = 276V Default = 437V Under voltage: Default = 192V Default = 304V
Trip response times (User adjustable)	Dry run (Under-load) 5 sec Under Voltage Less than 5 sec Over voltage Less than 5 sec
Recovery times (User adjustable)	Dry run (Under-load) 45 min default Overload 4 min default Under Voltage 4 min default Over voltage 4 min default
RS485 Technical interface	RS485 Bus Interface: asynchronous semi duplex 1200,2400,4800,9600 bps (default 9600bps) MODBUS protocol (RTU)
Alarms	Visual and audible alarm. Supports external alarm connection



To avoid 'nuisance' alarming, many of the default protection parameters have values with a wide tolerance. The installer is encouraged to optimise the settings to achieve optimum results

7. Display

The NXT-SPC display provides a real time indication of the operational mode and the current state of the controller, including real-time voltage/current and any error messages.

Only the icons relevant to the selected operational mode will display.

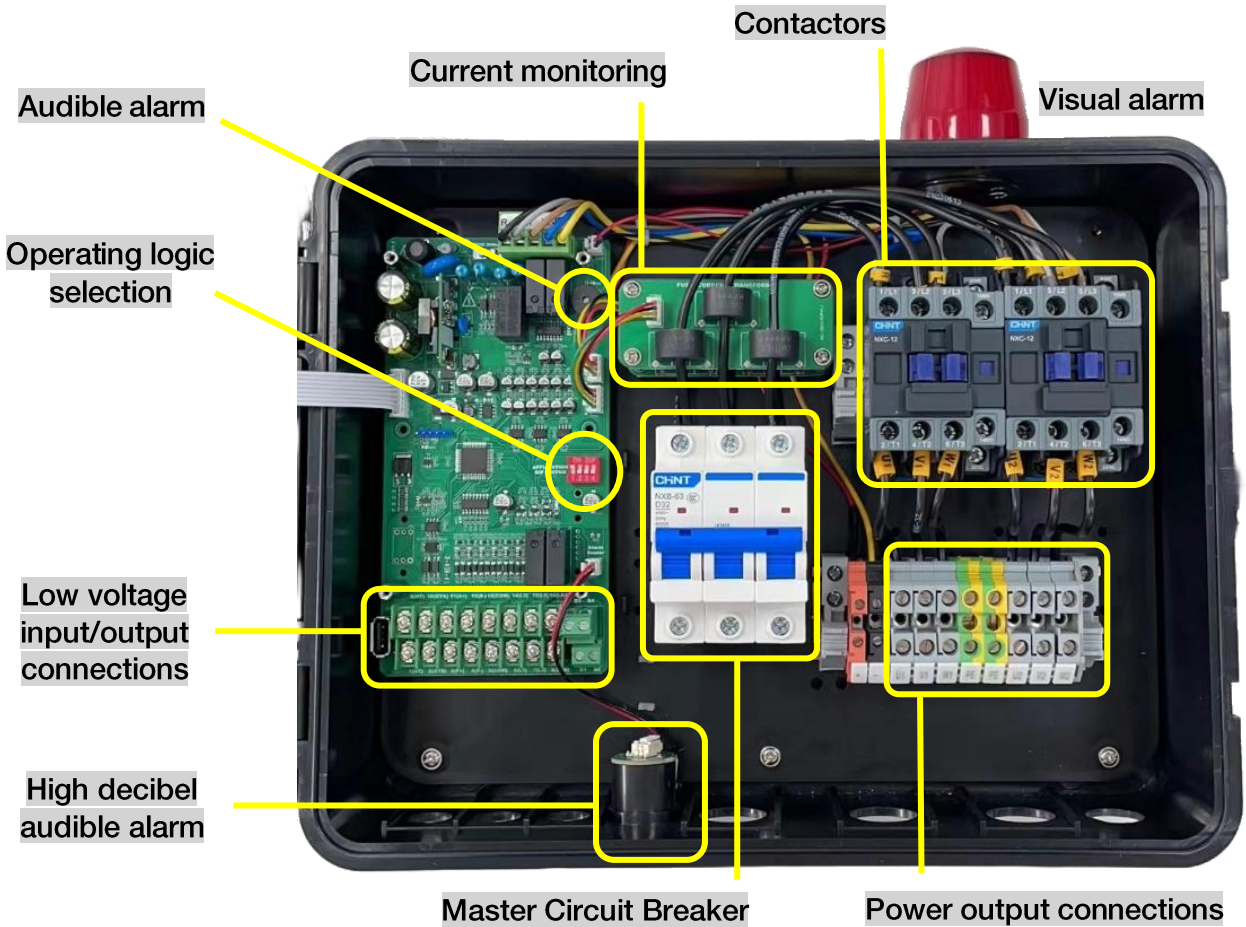
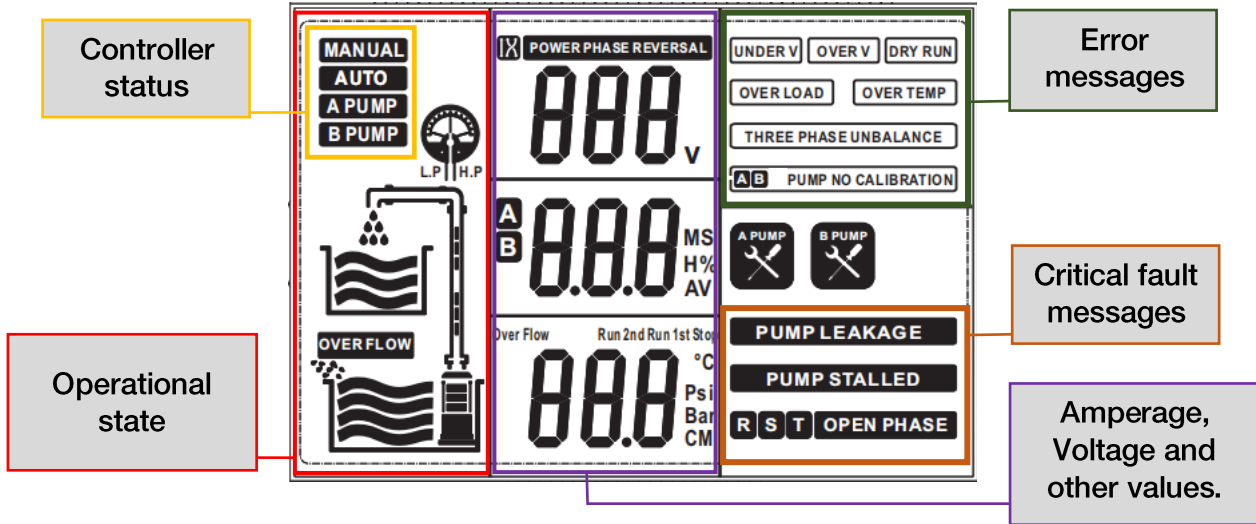

Image representative *only* (3 phase, dual pump model). Specific models will vary





7. Display con't

The NXT-SPC controller operates according to the pre-programmed logic for each 'mode'.

Changing the Dip Switches inside the controller then **cycling the power** will activate the selected logic mode.

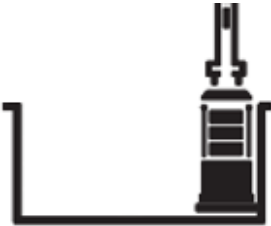
Examples of common applications are detailed later in this manual but with an understanding of how the controller responds to various inputs in each of the modes the controller can be used for application other than what is suggested.

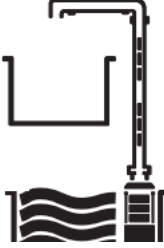
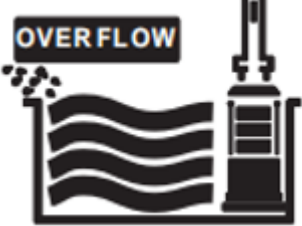
The appearance of the front display changes according to each mode and provides a visual indication to the state of the input signals.

	<p>Lack of source water</p>		<p>High pressure Low pressure</p>
	<p>Source water full</p>		<p>Destination low</p>
	<p>Overflow</p>		<p>Destination full</p>

Avoid installing the NXT-SPC where it could experience the following conditions:

- i. Where there is significant vibration and/or mechanical shock.
- ii. Where it could be exposed to corrosive liquids or gasses, or to flammable materials, solvents etc.
- iii. Extreme heat and cold. Operating range -25°C - 55°C.
- iv. Protect the controller from rain, moisture, humidity or dust

8. Electrical Connections

Always use an electrical outlet that is protected by Residual Current Device (RCD) Safety Switch with a trip current of 30mA or less. A Safety switch is required by Australian/New Zealand Standard AU/NZS 60335.1-2011.



All high voltage wiring must be connected by a suitably qualified technician.

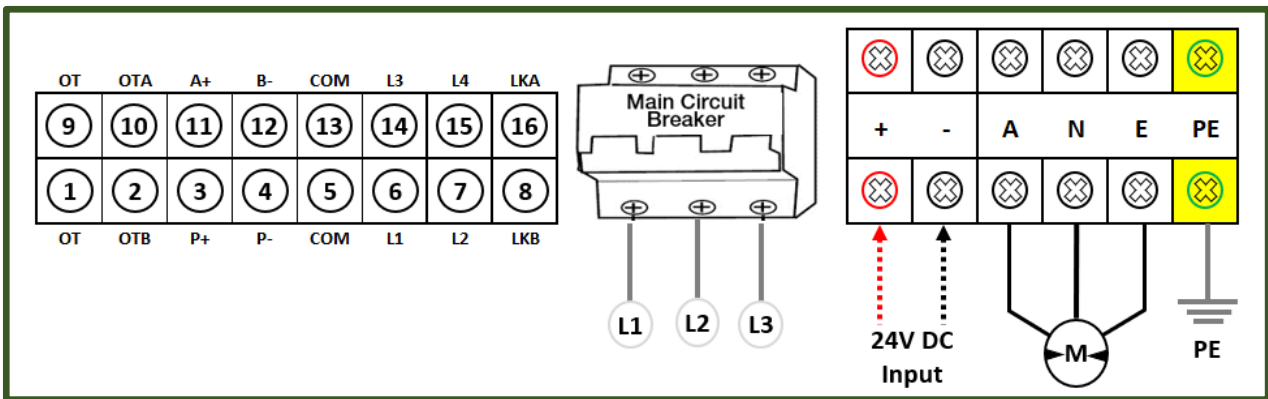
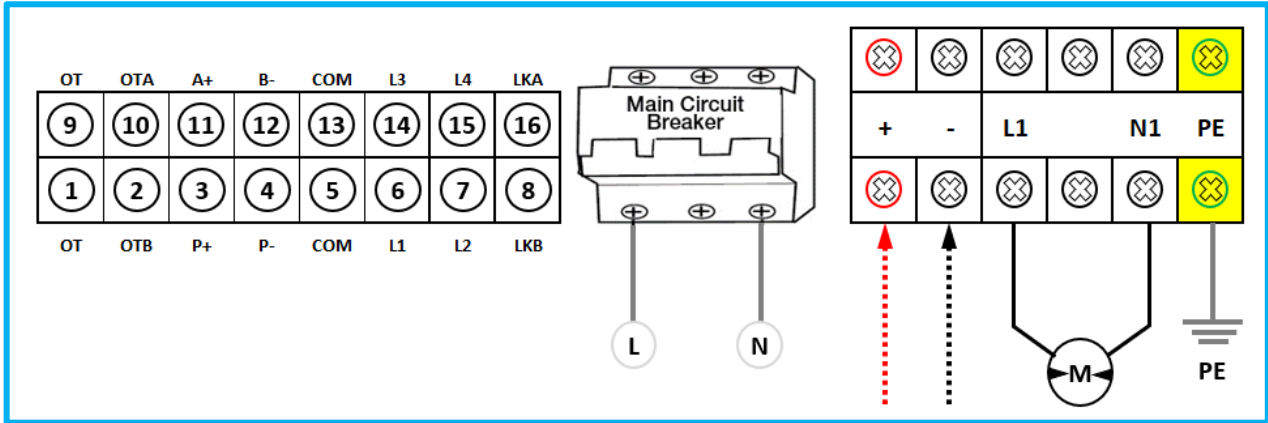

It is the responsibility of the installing electrical technician to ensure that the cable cross section (mm²) meets the requirements of AS/NZS 3008; taking into consideration the cable type, the cable length, the current draw and other relevant factors.

If in doubt, online resources exist i.e. Cable Size Calculator AS/NZS 3008 or seek advice from an electrical engineer or other suitably qualified person(s)

Output Terminals

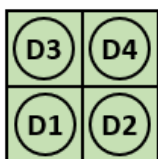

The NXT-SPC has two 'Dry Contact' terminals.

D1, D2 activate in the event of a critical fault

D3, D4 activate briefly whenever the controller is changed between its Automatic and Manual state (which requires physical intervention)



8. Electrical Connections cont

Pump over temperature protection sensor wiring terminal

Terminal	Definition
9(OT) + 10(OTA) <i>See Pg 6. Dip switch to 0*</i>	Pump over-temp protection sensor. Set to 0* is a N/O circuit, bridged unless connected. Standard thermals will open to peak signal and stop pump on overheat
9(OT) + 10(OTA) <i>See Pg 6. Dip switch to 1*</i>	PT100 connection. Set to 1* the circuit looks for the variable signal from a PT100 sub-board

Pump moisture protection sensor wiring terminal

Terminal	Definition
13(COM) + 16(LKA)	Pump leakage protection sensor

Dry contact (passive contact) point wiring terminal

Terminal	Definition
D1 + D2	Dry contact point for pump failure indication N/O circuit. Activates when there is a critical fault
D3 + D4	Dry contact for auto/manual status indication N/C circuit

4-20mA transmitter wiring – Modes 011 Drainage, 001 Boosting and 100 Transfer

Terminal	Definition
3(P+) + 4(P-)	4-20mA level/pressure transmitter

RS485 communication terminal

Terminal	Definition
11(A+) + 12(B-)	RS 485

Full factory reset

- Turn off power to the control panel,
- Press and hold the **STOP** button and reapply power
- When the display shows 099, release the **STOP** button.

9. Modbus

Main technical data	
Physical interface	RS485 Bus Interface: asynchronous semi duplex
Data format	1 start bit, 8 data bit, 1 stop bit, no verify 1 start bit, 8 data bit, 2 stop bit, no verify Default: 1 start bit, 8 data bit, 1 stop bit, no verify
Baud rate	1200,2400,4800,9600 bps (default 9600bps)
Communication address	Setting range of controller address: 1-126. 127: broadcast address, host computer broadcasting, slave machine response forbidden
Protocol type	MODBUS protocol (RTU)
Rated input voltage for SC	AC 240V/50Hz, single phase
Main installation data	
Wire communication distance	1200 m max by shield twisted pair cable (STP)for RS485 & CAN 5000 m max by STP and RS485 extender
STP	STP-120U one pair 20AWG for RS485 & CAN

10. Parameter Calibration



The pump must be able to pump water to enable correct calibration. Calibrated without water, overload and pump stalled errors may occur later. Calibration can be performed automatically as explained on Page 3 OR by accessing the User parameter menu #015 and manually inputting the desired value

When a new pump is installed, or an existing pump reinstalled after maintenance, erase the former calibration and a perform a fresh calibration.



To access parameter settings the controller should be in **Manual Mode** and the pump should NOT be running.

User Menu – Press the **STORE** button

Expert Menu – Press the **STORE** and **MODE** buttons for **5 seconds**

To enter a parameter, press the **STORE** button to advance to the next parameter and display the current value.

To change the value, press the **START** or **STOP** buttons respectively to increase or decrease the value.

To store the value and return to the main menu press **MODE** button.

To store all changes and exit the parameter menu hold the **MODE** button for **5 sec**

11. Program Parameters

Controller unlocked

Press **MODE** to switch between AUTO and MANUAL mode

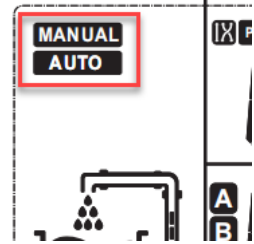

Controller locked (Parameter 011 active)

Press and hold **MODE** to switch to MANUAL mode

The controller operating mode will be displayed in the top left corner of the display

EXPERT MENU: Parameters 001 ~ 012

In MANUAL MODE, Press STORE then MODE and hold both until the controller beeps

ITEM	DEFAULT	OPERATION
001	3 sec	Pump stall delay time before applying protection To make provision for inrush current on pump start. Range 0 - 60
002	OFF	Boosting mode only - Repeated start protection Values greater than 0 represent maximum starts in a 1 minute period before repeat start protection activates Range: 0 – 50
003	OFF	Over-temp protection. Related to terminal connection 9 and 10. Dip switch #4 in the up position
004	OFF ON	Phase Reversal Protection - not applicable to single phase model When using the nXt DPC in conjunction with a VFD set to OFF
005	OFF ON	Open Phase Protection (monitors phase protection parameter #19)
006	96 hour	Anti Seize Protection: Cycle time. Range 1 – 254 hr
007	OFF	Boosting mode only - Start delay time Range Off or 1 – 254 sec
008	OFF	Boosting mode only – Stop delay time Range Off or 1 – 254 sec
009	OFF	Boosting mode only – Maximum run time Off or 1 – 254 min
010	OFF	Fault Alarm audio setting When a fault has occurred activating the alarm, after the time specified in parameter #010 the continuous alarm will switch to a ‘chirp mode’ (beeping for 1 sec at 5-minute intervals) Range: 00 – 24 hrs
011	OFF	Button lock function Off / On
012	00	Parity check 00 = None 01 = Odd parity 02 = Even parity

11a. Program Parameters cont

USER MENU – Parameters 013 – 030

In MANUAL MODE, Press and Hold store until the controller beeps

ITEM	DEFAULT	OPERATION
013	01	Controller ID (RS485 Comms) Range 00 – 254
014	04	RS485 Speed 01 = 1200 02 = 2400 03 = 4800 04 = 9600
015	Controller Dependant	Rated output i.e., pump calibration amperage
016	75%	Trip response ratio – Dry run (underload) protection Range: Off – 95%
017	130%	Trip response ratio – Over-load protection Range: Off – 170%
018	180%	Trip response ratio – Pump stalled / locked rotor protection Range: Off – 195%
019	20%	Trip response ratio – Phase imbalance 3 phase only Single phase, default is Off Range: Off – 50%
020	192V 332V	Trip voltage – Under Voltage Protection
021	276V 477V	Trip voltage – Over Voltage Protection
022	5 sec	Trip response time – Dry run Protection Range 1 – 553 sec
023	45 min	Recovery time – Dry run Protection Range 1 – 60 min
024	4 min	Recovery time – Overload protection Range 1 – 254 min
025	4 min	Recovery time – Under/Over Voltage Range 00 – 60 min
026	15 min	High Level Alarm Delay – Applies ONLY to Drainage Mode with floats connected to the pump Range Off, 1 – 254 min
4-20mA Input Mode 011 / 001 / 100 See Section 5 – Modes of Operation		
027	Mode Dependant	Sensor range Drainage/Transfer 0-200cm, Boosting 0 – 25 bar
028	Mode Dependant	Pump stop setting
029	Mode Dependant	Start pump setting
030	Mode Dependant	Overflow/Over pressure setting

If a replacement pump is installed, the previous calibration should be removed and a new calibration performed.



12. Understanding the control logic

NXT-SPC controllers effective, reliable means to provide better control and protection without the need for costly bespoke switchboards.

As detailed on Pg 6 there are 3 modes of operation: Drainage, Transfer and Pressure Boosting. Following are quick guides providing information which enables the installer to connect the inputs and become operational quickly.

To fault-find or de-bug an installation, it is best if the technician has an understanding of how the unit operates and what the logic sequence is.

The display provides a visual indication as to the state of the inputs, any alarm conditions or active timer status.

With an understanding of how the controller responds to various inputs in each of the modes the controller can be used for applications beyond what is suggested.

For instance, you can integrate the controller in line with a VFD pump controller to introduce additional control inputs or capitalize on the NXT-SPC controller's delay capabilities.

There are two input/control circuits:

Control Circuit A: COM / L1 / L2 and **Control Circuit B:** COM / L3 / L4

Transfer Mode, Pressure Boosting Mode

Set to **Transfer Mode** or **Pressure Boosting Mode**, the request to run is provided by the COM + L3 + L4 Destination/Supply Line circuit.

When this circuit is active, the internal logic checks the COM + L1 + L2 Source circuit to see if the inputs are in a position which indicates water is available.

Think of **Circuit B** as a Request to Operate, **Circuit A** as the Permission to Operate

Switched inputs:

Transfer Mode, control **Circuit B**, requires an open circuit to operate (i.e. float switch down indicating water required).

Pressure Boosting Mode, control **Circuit B** requires a closed circuit to operate (i.e. pressure falling and pressure switch closing)

Eliminating the Permission to Operate control (**Source Circuit A**) can be achieved by **Bridging COM + L1 + L2**. Operation is then controlled solely by the COM + L3 + L4 Destination/Supply Line circuit

Alternatively, COM + L3 + L4 can be bridged (**Pressure Boosting Mode**) or left open (**Transfer Mode**) and the on/off operation achieved via **Circuit A, COM + L1 + L2**

Note that when operating in Pressure Boosting Mode, controlled via **Circuit A**, the timer options (Start delay / Stop delay / Maximum run time as determined by Parameters 010, 011 and 012) will not operate. These parameters are applied to the COM + L3 + L4 Destination/Supply Line circuit ONLY

Drainage Mode:

Drainage Mode differs in that the assumption is that the output power is connected to a pump in a liquid chamber (the source) and that pump operation is related to liquid level.

Primary Pump Operation. A [float] switch input across **COM + L2** controls pump.

L1 can be bridged to **L2** OR an additional float connected **COM + L1** for greater level differential (**L1** and **L2** up/on, the pump starts; Both **L2** and **L1** returned to down/off position to stop the pump)

High Level Alarm. **COM + L4** triggers the audible and visual alarm AND ensures the contactor is closed to operate the pump

Floats

Source control - Single float

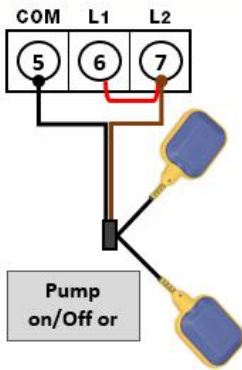

3 wire' floats allow for NO or NC wiring.

Connecting to the controller using the black and brown wires the circuit is closed when the float is up, open circuit when the float is down.

Source control - dual float

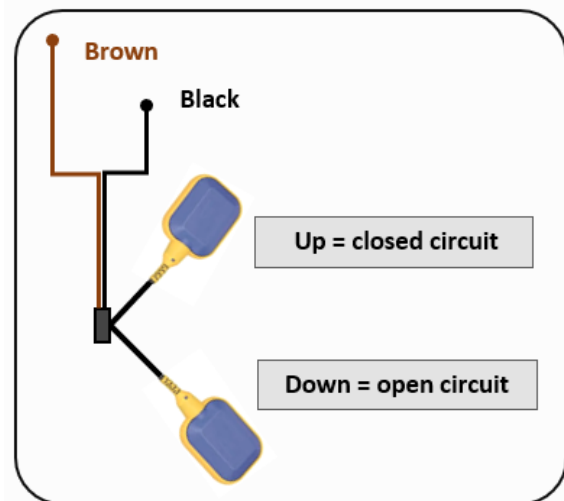
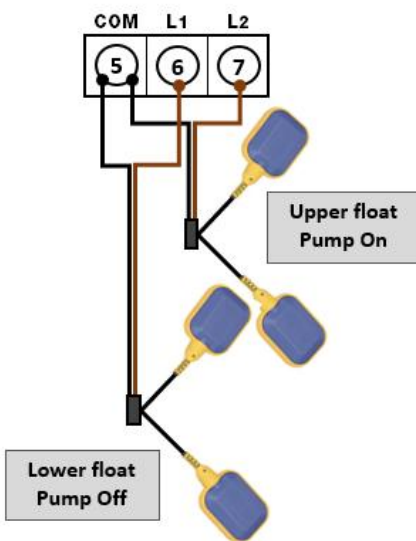

For greater differential, dual floats can be attached on the source inputs 5, 6 and 7. (**COM, L1, L2**)

When using a single float on the source input terminals #6 and #7 must be bridged.

12. Quick guide: Drainage Mode, float connected to pump



Set the dip switches on the main PCB and cycle the master circuit breaker

Parameter 026 Alarm Delay is available in this mode. *Software 1.01 only*

Default Setting 15min. Range: Off, 1 - 254

Set to this operational mode, the float connected to the pump controls its operation.

When the controller is in AUTO mode, there is power supplied to the pump continuously and the screen will display A START indicating the pump is ready to operate when its float reaches the up / ON position.

Connecting an additional float to COM (13) + L4 (15) provides a high level alarm function.

When the high level float reaches its up / ON position, Parameter #26 provides a delay period before the light and beeper activate. Default delay setting is 15 minutes.

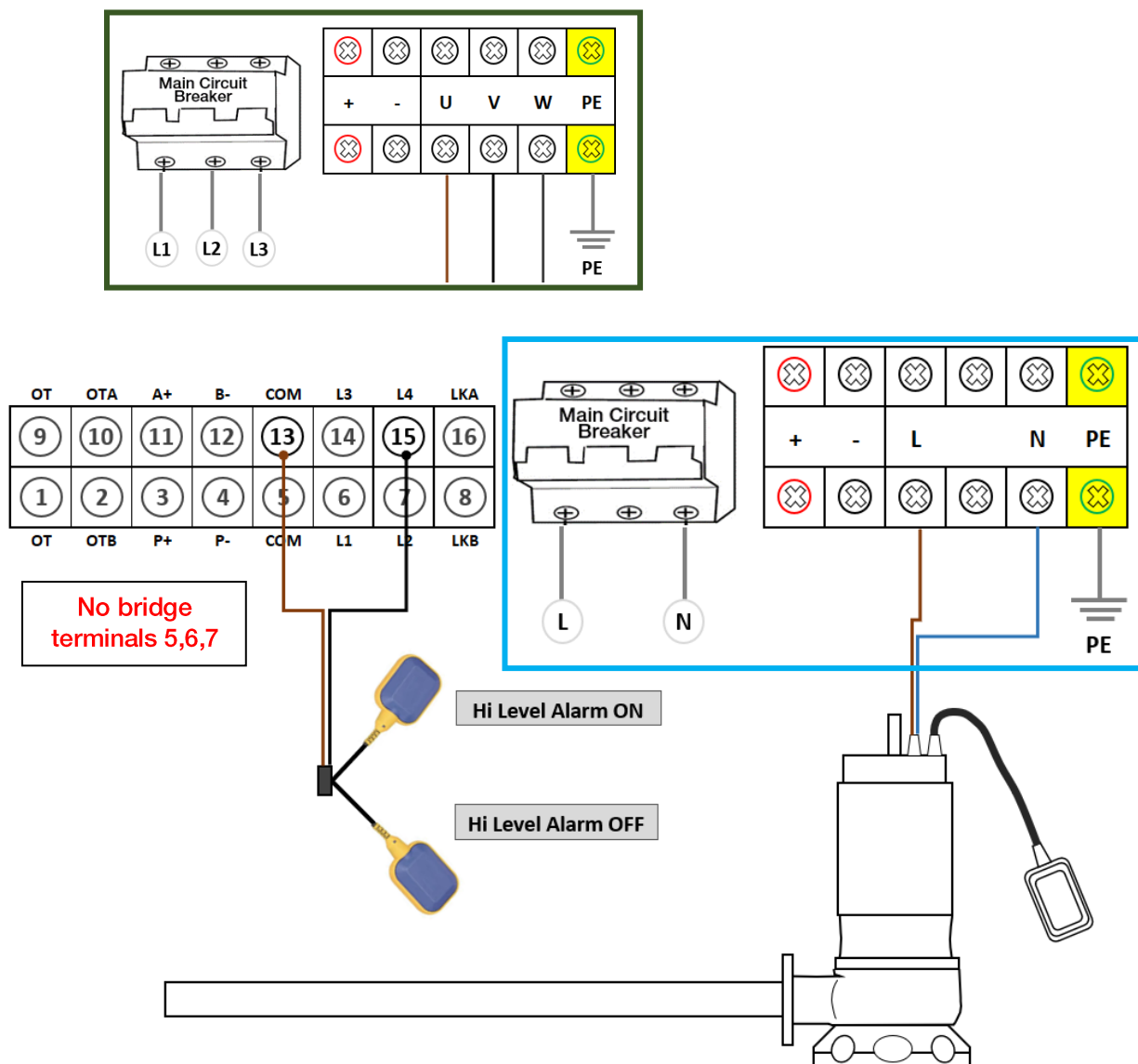

13. Quick guide: Drainage Mode, floats connected to control

This is the default mode as supplied



Set the dip switches on the main PCB and cycle the master circuit breaker

A pump with its own float can be used in this configuration so long as the operational level of Pump Stop Switch #1 is HIGHER than the float attached the pump.

Switched input - bridge terminals 6 and 7.

Pump switches on when the Pump Stop/Start switch is in the On (Up) position

Pump runs until the Pump Stop/Start switch is in the Off (Down) position

High-Level alarm triggers when the High-Level alarm switch is in the On (Up) position.

The alarm will turn off when the Hi Level alarm switch returns to the Off (Down) position.

The pump continues to run until the Pump Stop/Start switch is in the Off (Down) position

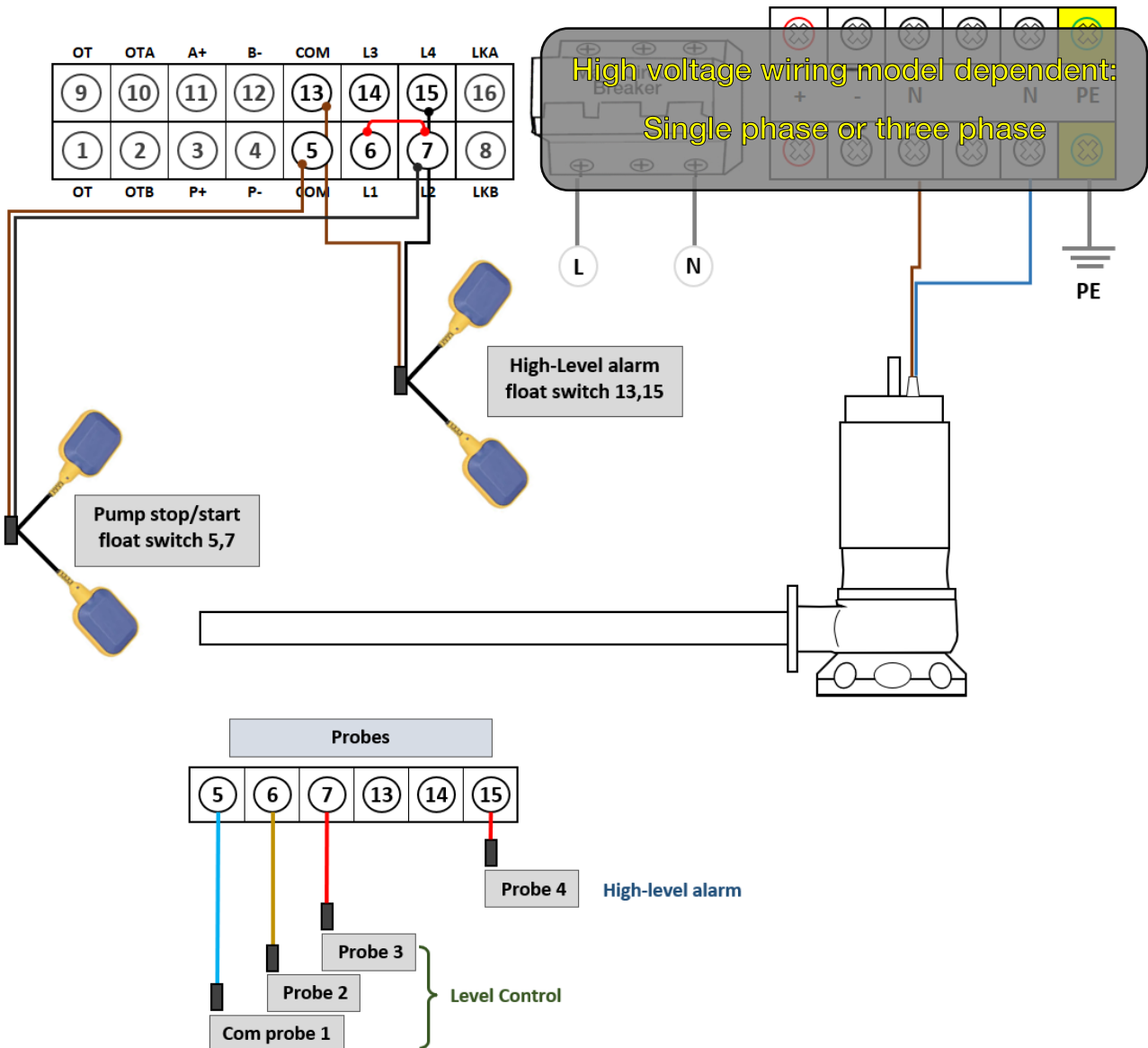

14. Quick guide: Transfer – source/destination control



Set the dip switches on the main PCB and cycle the master circuit breaker

Switched input:

Bridge terminals 6 and 7

Pump On/Off operation is requested by a float in the down (low level = ON) position at destination or a pressure switch in the delivery line dropping to cut-in pressure

A float switch or probes at the source controls whether the pump will run or not depending on the liquid level.

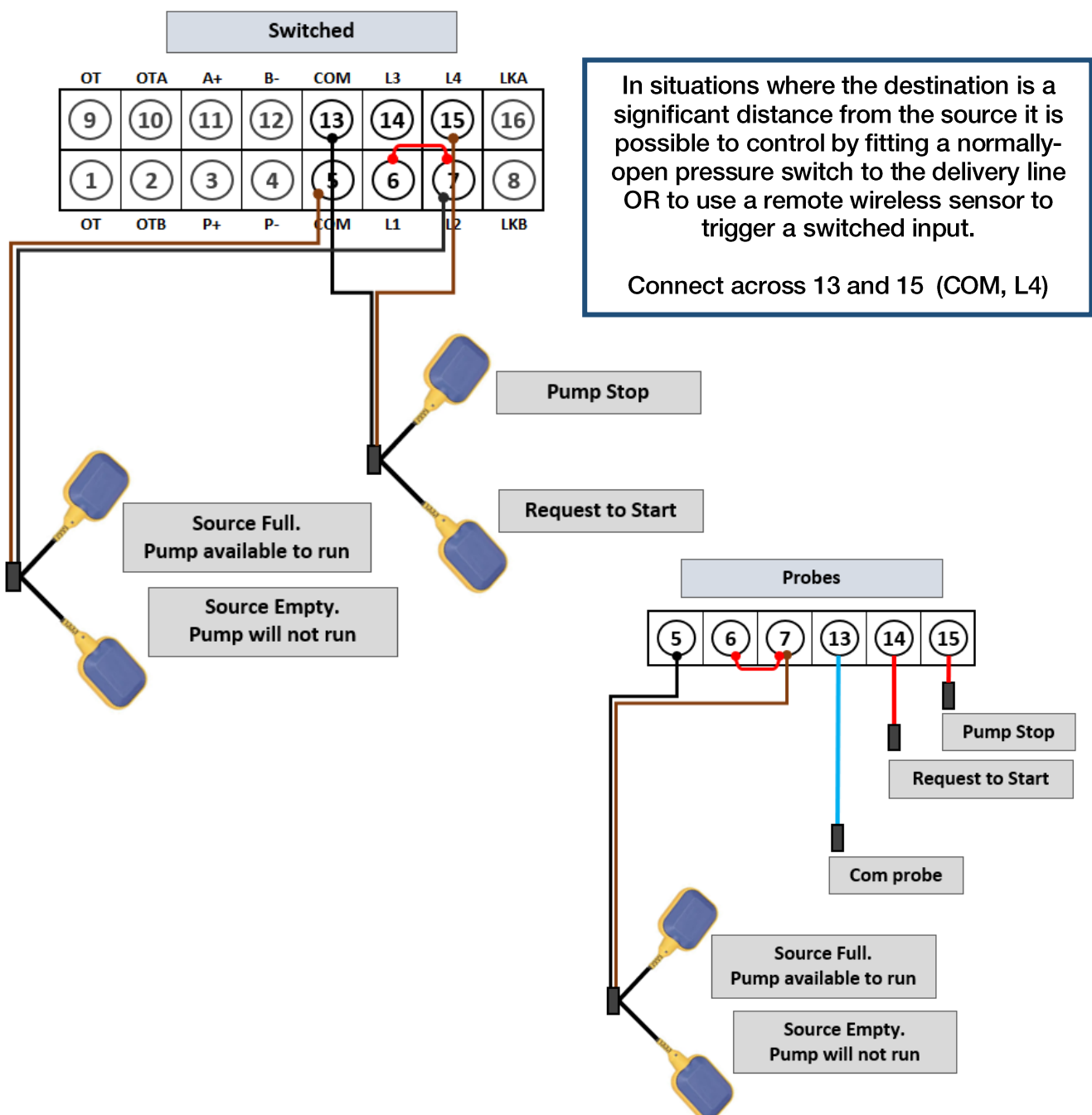

15. Quick guide: Pressure Boosting – switched input



Set the dip switches on the main PCB and cycle the master circuit breaker

Switched input:

Pump On/Off operation is controlled via a pressure switch on the delivery line.
Additional (optional) run/no run protection can be fitted at the source

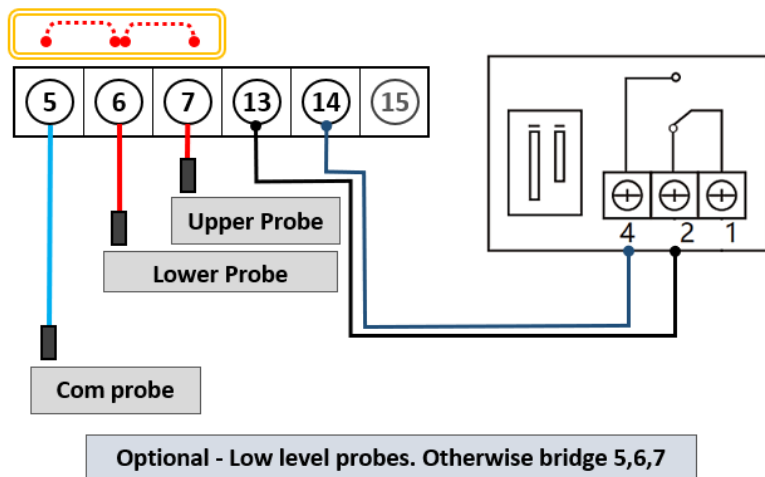
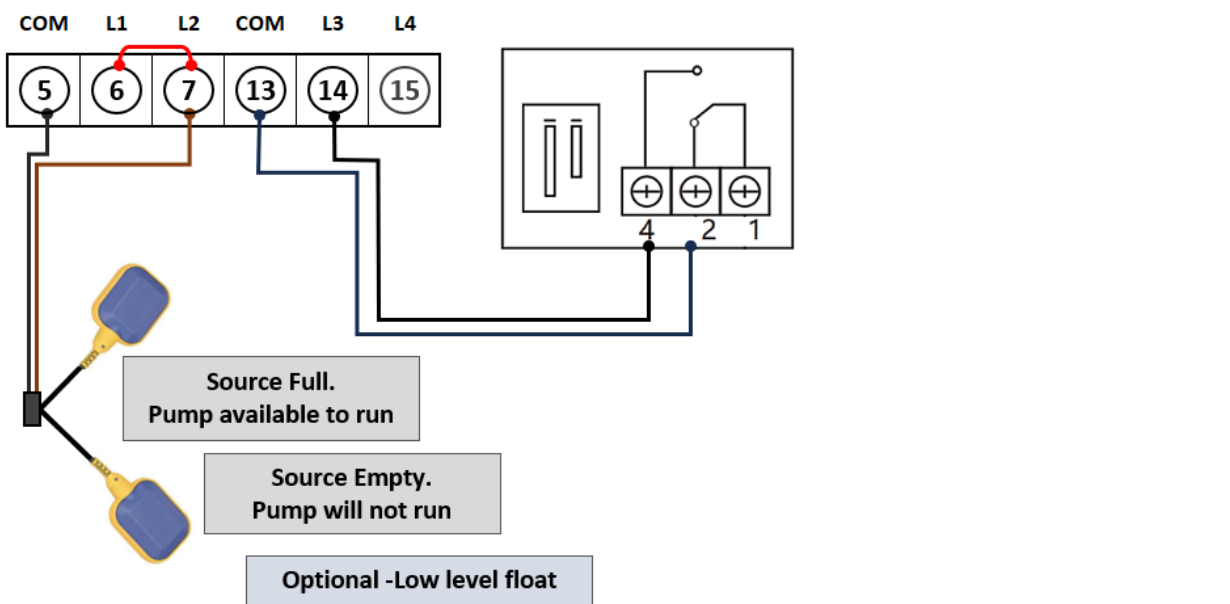
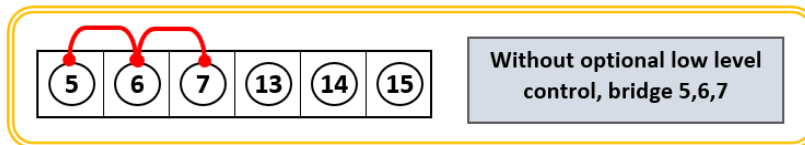

When the controller is set to Boosting Mode, Parameters 005 – 007 become available and can be employed to provide additional control.

- Start delay time Parameter 007 – Default Off
- Stop delay time: Parameter 008 – Default Off
- Maximum run time: Parameter 009 – Default Off

16. Quick guide: Drainage Mode, 4-20mA level transmitter



Set the dip switches on the main PCB and cycle the master circuit breaker

A pump with its own float can be used in this configuration so long as the Parameter 028 is HIGHER than the level at which the pump float switches the pump off

4-20mA input.



Transmitter accuracy is a percentage of the sensor full range. Choose the 4-20mA level transmitter with a measuring range according to depth of source tank.

The installer must enter the correct values for 4 parameter settings

- | | |
|---|---------------|
| 1) Level transmitter full measuring range | Parameter 027 |
| 2) Overflow alarm liquid level depth value | Parameter 030 |
| 3) Pump cut-in/start liquid level depth value | Parameter 029 |
| 4) Pump cut-out/stop liquid level depth value | Parameter 028 |

Set to drainage mode, parameters 027 to 030 are in centimetres (cm)
These are the control levels related to the source

Example:

Full measuring range:	200cm
Overflow alarm depth value:	150cm
Pump cut-in (start) depth value:	100cm
Pump cut-out (stop) depth value:	20cm

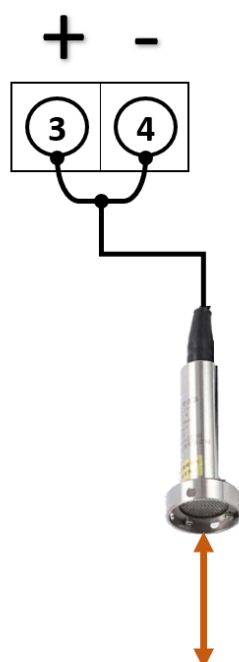

The size of the pump chamber and the inflow rate will determine to pump run time and time between restarts.

Excessive Pump Cycling is detrimental to pump operation and longevity.

Ensure the cut out / pump stop liquid level ensures sufficient motor submersion to aid cooling

Ensure the sensor is at least 50mm above the bottom of the sump

17. Quick guide: Transfer – source/destination control 4-20mA



Set the dip switches on the main PCB and cycle the master circuit breaker

4-20mA input.



Transmitter accuracy is a percentage of the sensor full range. Choose the 4-20mA level transmitter with a measuring range according to depth of source tank.

The installer must enter the correct values for 4 parameters

- | | |
|---|----------------------|
| 1) Level transmitter full measuring range | Parameter 027 |
| 2) Overflow alarm liquid level depth | Parameter 030 |
| 3) Pump cut-in/start liquid level depth | Parameter 029 |
| 4) Pump cut-out/stop liquid level depth | Parameter 028 |

Example:

Full measuring range:	200cm
Overflow alarm depth:	150cm
Pump cut-in (start) depth:	20cm
Pump cut-out (stop) depth:	100cm

Set to Transfer mode, parameters 027 - 030 are in centimetres (cm)
 These are the control levels related to the Destination

The Destination control (transducer) provides a request to start based on liquid level. The (optional) Source level control allows the pump to start only if there is sufficient liquid to position the source float in its up position

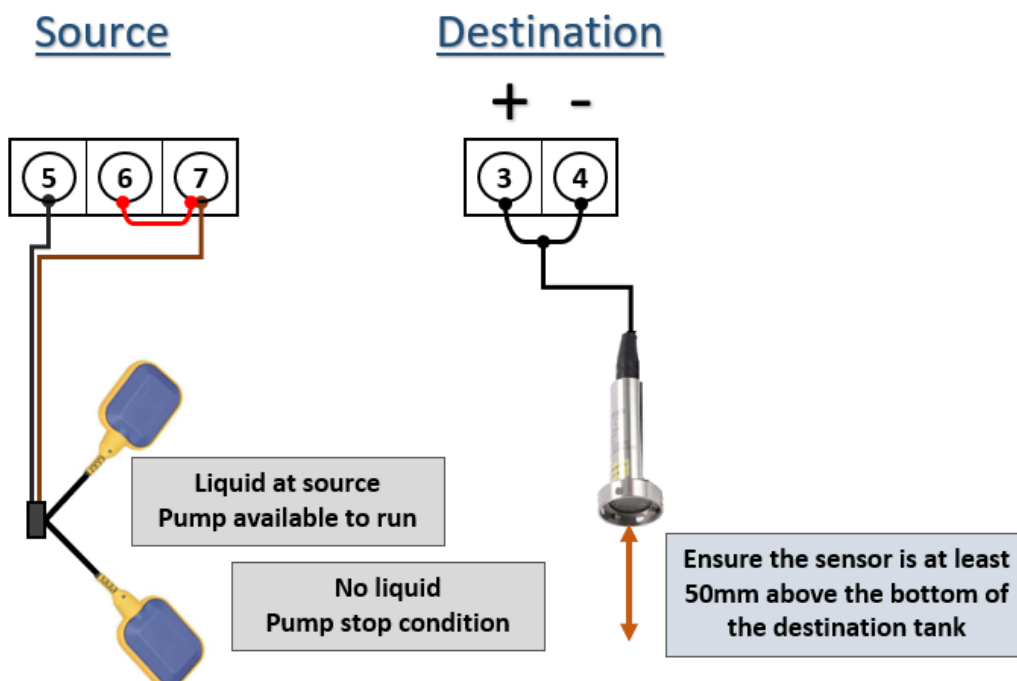

18. Quick guide: Pressure Boosting 4-20mA



Set the dip switches on the main PCB and cycle the master circuit breaker

4-20mA Pressure transducer:

Pump On/Off operation is controlled via a 4-20mA transducer on the delivery line.

Additional (optional) run/no run protection can be fitted at the source

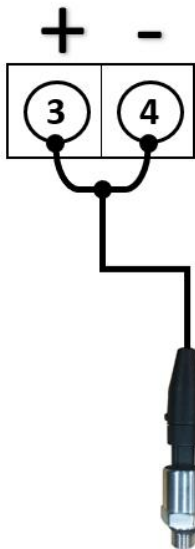

- 1) Pressure transmitter full measuring range in bar **Parameter 027**
- 2) Over pressure alarm value **Parameter 028**
- 3) Pump cut-out (stop) pressure **Parameter 029**
- 4) Pump cut-in (start) pressure **Parameter 030**

Set to Boosting mode, parameters 027 - 030 are in bar
These are the control pressures in the delivery line

Example: Full measuring range: 25 bar
Over pressure alarm value: 8 bar
Pump cut-in (start) pressure: 4 bar
Pump cut-out (stop) pressure: 6 bar

Fitted to delivery line

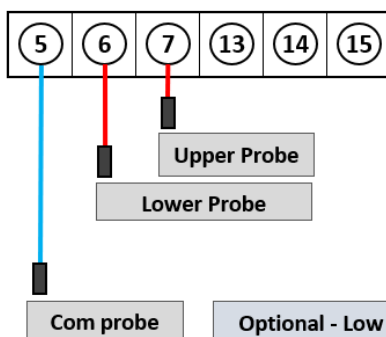
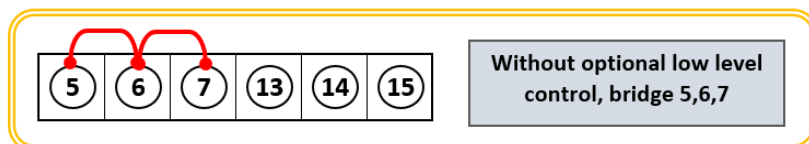

OR

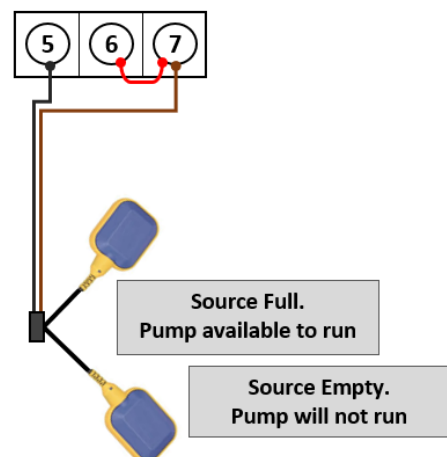

19. Backup power supply

In some regions, battery backup for the high-level alarm is mandated.

Connecting a 24v battery pack will maintain the alarm and control circuit in case of a mains power failure.

When mains power falls, the unit will display in input voltage (24V) and the Under-Voltage warning message will display on the screen. The pump will not attempt to run, the backup power supply is only to ensure the Hi-Level alarm is able to function for as long as the backup battery maintains its output

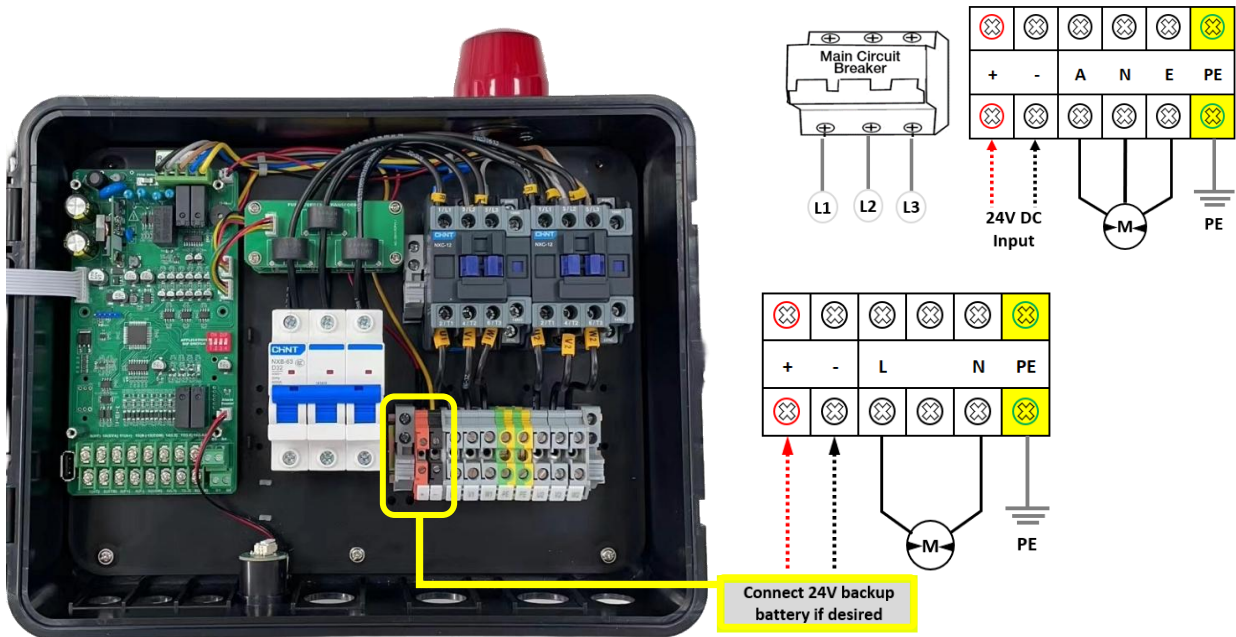

External Alarm

The NXT-SPC has an inbuilt audible / visual alarm.

An additional 24V DC external, remote alarm can be fitted and wired in parallel.

PN 811785

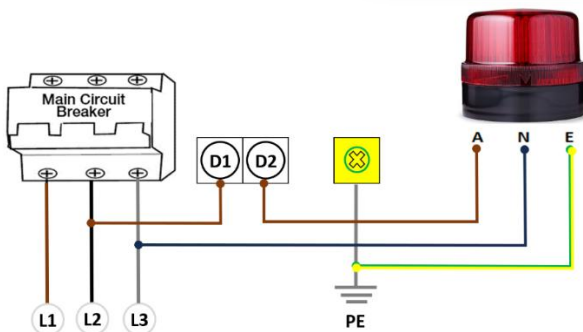
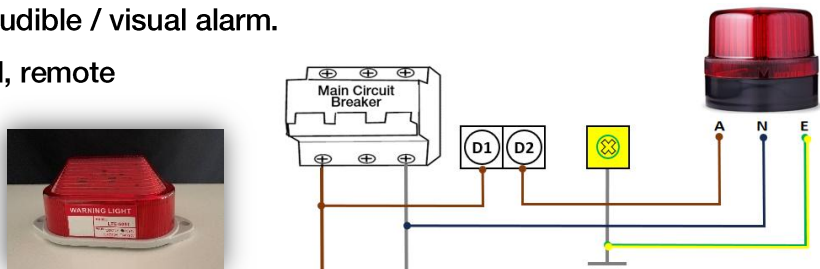

Alarm test:

Located on the rear of the display

20. Fault Messages

Fault Message	Possible Cause	Potential Solutions
UNDER V	The actual running voltage is lower than the calibrated voltage parameter 022 . The pump is in an under-voltage protection state	The controller will attempt to restart the pump every 5 minutes until line voltage is restored to normal If this fault occurs repeatedly, report low line voltage to the power supply company
OVER V	The actual running voltage is higher than the calibrated voltage parameter 023 . The pump is in over-voltage protection state	The controller will attempt to restart the pump every 5 minutes until line voltage is restored to normal If this fault occurs repeatedly, report high line voltage to the power supply company
PUMP STALLED	The pump motor running amperage has exceeded the normal (calibrated) running amperage by more than parameter 020 (default value 175%) This could be due to physical jamming or a mechanical issue. If the pump stalled error occurs repeatedly at commissioning check the controller rating is matched to the pump	Pump Stalled is a 'critical error' and will not automatically reset. Isolate the power supply and inspect the pump for anything which has caused the sudden increase in load
OVER LOAD	Pump motor running amperage exceeds the normal (calibrated) running amperage by more than parameter 017 (default value 130%)	Isolate the power supply and inspect the pump for anything which is causing the pump to draw more amperage than the initial calibration value
UNDER LOAD	Pump motor running amperage is less than the normal (calibrated) running amperage by more than parameter 016 (default value 75%)	Under-load is sometimes referred to as Dry-run protection as a pump motor will draw less current when there is no load.
OPEN PHASE	The power supply has lost a phase.	Check fuses and wiring.
PHASE IMBALANCE	Three phase model only The incoming voltage (ampere) between three phases (R/S/T) differs by more than $\pm 15\%$	The controller will attempt to restart the pump every 4 minutes until the voltage (amperage) between three phases is restored to normal
POWER PHASE REVERSAL	Three phase model only Sequence of the incoming wiring (R/S/T) is incorrect	Change the sequence of the wiring
PUMP NO CALIBRATION	Calibration not complete	Check the calibration Parameter 015

21. Accessories

Image	Description	Part #
	Capacitance Probe	805321
	4-20mA pressure transducer 1MPA	802680
	4-20mA level transducer 2m	804528
	SK12(5M) H05 10 amp SK12(10M) H05 10 amp SK12(20M) H05 10 amp SK12(30M) H05 10 amp FSK1 (5m) H07 10 amp FSK1 (10m) H07 16 amp FSK1-20 (20m) H07 16 amp	700965 700962 700963 700964 809941 700610 700611
	FSK1.1(10m) H07 10 amp	801125
	Float switch counter-weight	700967
	Pressure switch (NC) 6 bar Pressure switch (NC) 12 bar Reverse acting pressure switch (NO) 5.5 bar Reverse acting pressure switch (NO) 10 bar	701440 701380 809863 809864

21. Warranties – Terms and Conditions

This warranty is given in addition to the consumer guarantees found within the Australian Competition and Consumer Act 2010 (Cth) for goods purchased in Australia and the Consumer Guarantees Act 1993 NZ for goods purchased in New Zealand:



1) White International Pty Ltd / White International NZ Ltd (White International) warrant that all products distributed are free from defects in workmanship and materials, for their provided warranty period as indicated on the top or opposite side of this document. Subject to the conditions of the warranty, White International will repair any defective products free of charge at the premises of our authorised service agents throughout Australia and New Zealand if a defect in the product appears during the warranty period. If you believe that you have purchased a defective product and wish to make a claim under this warranty, contact us on our Sales Hotline on 1300 783 601, or send your claim to our postal address or fax line below and we will advise you as to how next to proceed. You will be required to supply a copy of your proof of purchase to make a claim under this warranty.

2) This warranty excludes transportation costs to and from White International or its appointed service agents and excludes defects due to non-compliance with installation instructions, neglect or misuse, inadequate protection against the elements, low voltage or use or operation for purposes other than those for which they were designed. For further information regarding the suitability of your intended application contact us on our Sales Hotline on 1300 783 601. If you make an invalid claim under this warranty, the original product will be sent back to you unrepai red.

3) This warranty refers only to products sold after the 1st January 2012, and is not transferable to another product type and only applies to the original owner, purchaser or end user, and is in addition to the consumer guarantees found within the Competition and Consumer Act 2010 (Cth) for goods purchased in Australia and the Consumer Guarantees Act 1993 (NZ) for goods purchased in New Zealand.

4) Our goods come with guarantees that cannot be excluded under the Australian Consumer Law. You are entitled to a replacement or refund for a major failure and for compensation for any other reasonably foreseeable loss or damage. You are also entitled to have the goods repaired or replaced if the goods fail to be of acceptable quality and the failure does not amount to a major failure. 2 YEAR WARRANTY

5) To the fullest extent permitted by law, White International excludes its liability for all other conditions or warranties which would or might otherwise be implied at law. To the fullest extent permitted by law, White International's liability under this warranty and any other conditions, guarantees or warranties at law that cannot be excluded, including those in the Competition and Consumer Act 2010 (Cth), is expressly limited to: (a) in the case of products, the replacement of the product or the supply of equivalent product, the payment of the cost of replacing the product or of acquiring an equivalent product or the repair of the product or payment of the cost of having the product repaired, is at the discretion of White International or a 3rd party tribunal elected under the Competition and Consumer Act 2010 (Cth) for goods purchased in Australia and the Consumer Guarantees Act 1993 (NZ) for goods purchased in New Zealand; and

6) To the fullest extent permitted by law, this warranty supersedes all other warranties attached to the product or its packaging.

7) In the case of services, supplying the services again or the payment of the cost of having the services supplied again, is at the discretion of White International or a 3rd party tribunal elected under the Competition and Consumer Act 2010 (Cth) for goods purchased in Australia and the Consumer Guarantees Act 1993 (NZ) for goods purchased in New Zealand. 8) Our warranty commences from the date of purchase of the above-mentioned pumps. Proof of purchase is required before consideration under warranty is given.

Record your date of purchase in the space below and retain this copy for your records.

Date of Purchase**Model Purchased**



www.whiteint.com.au

1300 783 601

www.whiteint.co.nz

0800 509 506

Please always refer to our website for further technical information & new product innovations

Disclaimer: Every effort has been made to publish the correct information in this manual. No responsibility will be taken for errors, omissions or changes in product specifications.

© 2025 Copyright White International Pty Ltd

TM ® - WARNING: Please be aware that various brands & products depicted within this document are subject to trademark, patent or design registrations. Infringement of any intellectual property contained within this document without express written authority by the appropriate intellectual property holder may result in further legal action to be taken. For any queries regarding use of the contained information please feel free to contact White International Pty Ltd.